

SERVICE AND OPERATION MANUAL

MTG- XX02XT/XN OPEN FRAME XVGA COLOR MONITORS

MTG-1702XT/XN : 17INCH, FST

MTG-1902XT/XN : 19INCH, FST



Information in this publication current as of Jun, 2003.

Information subject to change as display technology advance.

This publication produced by TOVIS Engineering Division.

This monitor has been designed and manufactured to deliver high performance video. For continued peak Performance use safe operation, only high quality TOVIS replacement parts or their exact specified Equivalent When servicing.

SAFETY PRECAUTIONS AND WARNINGS

Service Warning

This display contains HIGH VOLTAGE capable of delivering LETHAL quantities of energy. Service should only be attempted by trained personnel familiar with the potential dangers inherent with voltage equipment.

Safety Related Component Warning

Certain components used in TOVIS color monitors are critical for safe operation of the display. These parts Number are marked by () in the parts list and on the schematic diagram it is essential that these Safety critical components be replaced only with exactly specified components to prevent the Possibility of excessive X-radiation emission, electrical shock, fire, or premature component failure.

Modifying the original design without written approval from TOVIS is expressly forbidden, will void the original Parts and labor warranty, and may result in creating a hazardous situation.

X-RADIATION WARNING

COMPONENTS WHICH MAY AFFECT POTENTIAL EXCESS EMISSION OF X-RADIATION IN THE HORIZONTAL DEFLECTION AND HIGH VOLTAGE CIRCUITS (INCLUDING THE PICTURE TUBE) ARE TO BE USE ONLY TYPE AND RATING OF REPLACEMENT COMPONENT AS SHOWN IN THE PARTS LIST.

1. The only potential source of X-radiation emission is the picture tube. When the high voltage and horizontal deflection circuits are operating correctly there is no possibility of excess X- radiation emission. NEVER attempt to modify these circuits.
2. Periodically check the high voltage with a reliably calibrated meter for values not in excess of Manufacturer's recommendations. See high voltage Shut-down Circuit, page 4, for further details.

CRT Warning

All picture tubes used in TOVIS monitors are equipped with an integral implosion protection system.

The picture Tube is, however, a highly evacuated component whose outside surfaces are subject to strong external forces. Care must be exercised so as not to bump or scratch the tube during installation or servicing as this may cause the tube to implode resulting in possible personal injury and property damage. Shatter-proof goggles must be worn by Individuals while handling the CRT or installing the display in the cabinet. Do not handle The CRT by the neck.

1. Always ensure the high voltage at the anode cap is fully discharged prior to handling or service.
2. Replace picture tube only with same type and number.

Product Safety and Service Guidelines

1. Service should be performed only after reading all of the warnings and precautions in this manual and as Labeled on the CRT and chassis.
2. Where a short circuit has occurred, replace all components that indicate evidence of overheating or poor Connection on all plastic connectors.
3. Inspect wiring for frayed leads and damaged insulation when service is required, observe original lead Dress is followed as from the factory, especially in the high voltage circuitry area.
4. All protective devices must be reinstalled per original design.

PERFORMANCE AND OPERATING DATA

1. Power Supply

- *Power Input: 100VAC ~ 254VAC, 50/60Hz
- *Fuse Rating: 250V, 50T 3.15A
- *Power Consumption:

Size	17"	19"
W(Max)	100	130

2. Signal Input

- *Video Input: Analog, Positive Signal (0.7V p-p)
- *Horizontal Sync: TTL Level, Positive or Negative Pulse
- *Horizontal Scan: 28KHz ~ 70KHz
- *Vertical Input: TTL Level, Positive or Negative Pulse
- *Vertical Scan: 40Hz ~ 160Hz
- *Resolution-Mode

Hf	Vf	Resolution	H Range	V range
31KHz	70Hz	720x400	28 ~ 32.9	68 ~ 72
31KHz	60Hz	640x480	28 ~ 32.9	58 ~ 62
35KHz	86Hz	1024x768	33 ~ 35.9	84 ~ 88
38KHz	75Hz	640x480	36 ~ 40.9	73 ~ 77
38KHz	60Hz	800x600	36 ~ 40.9	58 ~ 62
47KHz	75Hz	800x600	41 ~ 51.9	73 ~ 77
48KHz	72Hz	800x600	41 ~ 51.9	70 ~ 74
48KHz	60Hz	1024x768	41 ~ 51.9	58 ~ 62
53KHz	85Hz	800x600	52 ~ 61.9	83 ~ 87
56KHz	70Hz	1024x768	52 ~ 61.9	68 ~ 72
60KHz	75Hz	1024x768	52 ~ 61.9	73 ~ 77
64KHz	60Hz	1280x1024	62 ~ 70	58 ~ 62
68KHz	85Hz	1024x768	62 ~ 70	83 ~ 87

3. Picture Tube

The Cathode Ray Tube shall be a SAMSUNG Normal & Dyna-Flat or equivalent

Size	Dot Pitch	Phosphor	P/N
17 FST	0.26mm	P22	M41QAR361X
19 FST	0.26mm	P22	M46QCE261X

4. Pincushion

- 5% Maximum (All Brightness)

5. MTBF

- 20,000 Hours Minimum

6. Leakage Current

- To chassis ground, at 220VAC, 50Hz (Line/Neutral in common)
- 0.195mA Maximum

7. High Pot

- Line/Neutral in common to secondary/chassis, 1500VAC 60Hz for 1 second
- 2.0mA Maximum, No Breakdown

8. Implosion Protection

- Provided by band and mounting lugs

9. Magnetic Shielding

- Internal

10. X-Radiation

- 0.50mR/hr Maximum

11. Mis-convergence

- Center : 0.30mm Maximum
- Corners : 0.45mm Maximum

12. Non-Linearity

- Using a vertical and horizontal symmetrical cross hatch pattern to equation for non-linearity will be

$$\text{Non-linearity (\%)} = \frac{(\text{largest grid minus the smallest grid})}{(\text{largest grid plus the smallest grid})} \times 100.$$
- Standard Mode : 5% maximum
- Other Modes : 10% maximum

13. Temperature

- Operating: 0° ~ 50°C
- Storage: -10°C ~ 75°C
- Humidity: 10% ~ 90%(Non-condensing)

14. Power Save Mode

- Shall be initiated by holding the Vertical Sync input Low (0.5V) and shall reduce the power to less than 20 Watts.

15. Degaussing

- Automatic at power-up and software via control Switch "SEL"

16. Regulation (Static)

- The horizontal and vertical size will change less than 2mm for a 25% white level abrupt luminance change.

PERFORMANCE AND OPERATING DATA

17. Display Stability for Temperature

The temperature is cycled from 25°C to 0°C, and from 25°C to 50°C the video size and centering drift will not exceed 5mm horizontally or 4mm vertically. (Measured after a 20 min. warm-up period at 25°C)

18. Monitor Test Specifications

<u>Parameter</u>	<u>Size</u>	<u>Normal</u>	<u>Tolerance</u>
H/V (0uA Beam Current)	17 FST	26.0KV	+/- 500V
	19 FST	27.0KV	
G2	17 FST	530V	+/- 10V
	19 FST	560V	
Brightness	17 FST	0.4FL	+/- 0.3FL
	19 FST	0.5FL	
Contrast (10% Window Box)	17 FST	60.0FL	+/- 5FL
	19 FST	60.0FL	
White Balance(9300)		X: 0.281	+/- 0.015
		Y: 0.311	+/- 0.015
White Balance(6500)		X: 0.313	+/- 0.015
		Y: 0.329	+/- 0.015

*Test Mode: VGA 640 x 480(Fh: 31KHz, Fv: 60Hz)

*Signal: BSG-170 (BARO)

19. WARRANTY

Manufacturer warranty 2 years parts and labor.
(Except on C.R.T)

USER ADJUSTABLE CONTROLS

There are four switches on the control panel. Adjustable controls allow the best display status for individual preferences

Key Function

MODE

*MODE - Call the Main-Menu OSD.

SEL/DEGAUSS

*SEL – Select the function (sub-Menu OSD) on the Main- Menu OSD.

*DEGAUSS – Do degaussing in state that the OSD isn't displayed.

DOWN/UP

*When the Main-Menu is displayed, can search each function using these keys.

*When the Sub-Menu is displayed (after select the function), can change each state of the screen using these keys.

O.S.D Control Sub-P.C.B



O.S.D CONTROL METHOD

1) Control items.

Location	Adjustment Method	Function
SUB PCB	OSD Control	Brightness Contrast Horizontal Position Horizontal-Size Vertical Position Vertical-Size Rotation Pincushion Trapezoid Parallelogram Pin balance Parallelogram
MAIN PCB VR control	VR301 VR501 VR502 VR503 FBT	Sub H-size H.V Adjustment ABL Adjustment Sub-Bright Focus and Screen

OSD Controls

: User's control.

A. BRIGHTNESS ADJUSTMENT

- 1) Press the "MODE" key then Main-Menu OSD come out as below Figure.
- 2) Search "BRIGHTNESS" sub-menu using "UP/DOWN" key on the Main-Menu OSD.
- 3) Select the "BRIGHTNESS" by pressing "SEL" key. Then The "BRIGHTNESS" OSD color changes from yellow to red.
- 4) Adjust Brightness as much as you want using "UP/DOWN" key.
- 5) After finish the Brightness adjust, Press the "MODE" key then the "BRIGHTNESS" OSD color changes from red to yellow and changed brightness value saved automatically.
- 6) If you want to adjust other function (sub-menu), Search your wanting sub-menu like "CONTRAST" using "UP/DOWN" keys and then adjusts as same way as item 3), 4) and 5).
- 7) Press the "MODE" key again to finish the adjustment then the OSD disappeared.

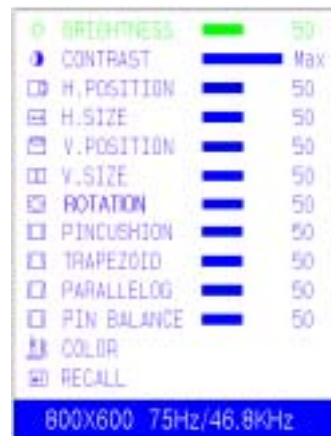
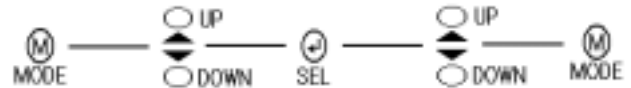

- B. CONTRAST** Adjusted as same way as above
- C. H.POSITION** Adjusted as same way as above
- D. H-SIZE** Adjusted as same way as above
- E. V.POSITION** Adjusted as same way as above
- F. V-SIZE** Adjusted as same way as above
- G. PINCUSHION** Adjusted as same way as above
- H. TRAPEZOID** Adjusted as same way as above
- I. PARALLELOG** Adjusted as same way as above
- J. PINBALANCE** Adjusted as same way as above

USER ADJUSTABLE CONTROLS

K. COLOR ADJUSTMENT

Press the "MODE" key then Main-Menu OSD come out as below figure.

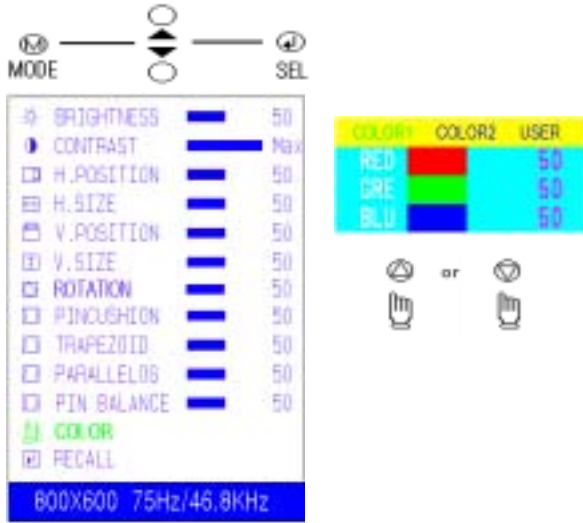

1) Search "COLOR" sub-menu using "UP/DOWN" key on the Main-Menu OSD.

- 2) Select the "COLOR" by pressing "SEL" key, then the color Sub-Menu OSD comes out as below figure.
- 3) Search "USER" using "UP/DOWN" key ("COLOR1" and "COLOR2" is adjusted in factory by auto-alignment machine)
- 4) Press "SEL" key to adjust "RED", "GREEN" and "BLUE", The each "RED", "GREEN" and "BLUE" is selected by pressing the "SEL" key and selected item changes OSD color from white to it's own color as character (ex: "RED" goes to red color)
- 5) Adjust "RED", "GREEN" or "BLUE" using "UP/DOWN" key.
- 6) Press "MODE" key to finish the color adjustment then the OSD goes back to Main-Menu.
- 7) Press the "MODE" key again to finish the adjustment then the OSD disappear.

L. RECALL

When press the "RECALL" key, all user's adjustment value are erased and covered by factory adjustment value. At first stage without any user's adjustment, The monitor set-upped by factory adjustment value.

Factory control (On Screen Display)

This monitor has two-adjustment mode. One is for user's own adjust and other is for factory adjustment only. But sometimes it needs to adjust at factory adjustment mode for repair or development person. Adjustment at the factory adjustment mode needs more careful compare to user adjustment mode. Because after finish the adjustment at factory mode, If there are some mistake, can not recover to before adjustment at the user mode, If there are mistake at the user mode, can recover using "RECALL" function (refer to "L. RECALL").

A. Factory mode entering.

Press the "UP" and "DOWN" key simultaneously until OSD comes out as below.

The OSD of factory mode is same format with user mode except color of bottom line. (User mode is blue; factory mode is red as below)

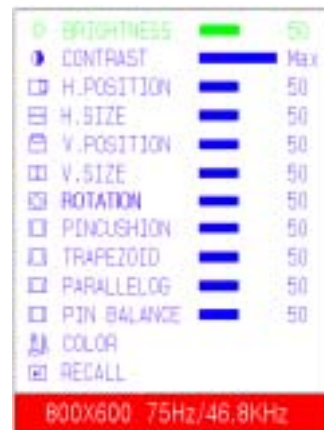
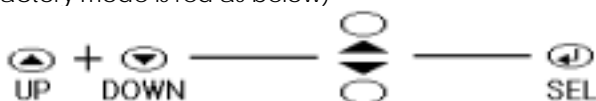

B. Exit and save

- 1) After finish the adjustment; search "RECALL" using "UP/DOWN" key.
- 2) Press "SEL" key until OSD disappear then the adjusted value saved and exit from the factory mode.

Factory control(On Screen Display)

C. Color Adjustment

All adjustment method is same with user's control mode except "COLOR".

- 1) Before adjust "COLOR", "CONTRAST" and "BRIGHTNESS" have to fix maximum.
(It's a TOVIS's reference condition.)
- 2) At the factory mode, search "COLOR" using "UP/DOWN" key.
- 3) Select "COLOR" by pressing "SEL" key then color sub-menu comes out as top below figure.
- 4) Search a color temperature which you want to adjust (gain or bias) using "UP/DOWN" key.
("GAIN" means high-beam area's adjustment and "BIAS" means low-beam area's adjustment.)
- 5) Select an any item as wanting by pressing "SEL" key then the OSD changes to under sub-menu as below figure.
- 6) Adjust color temperature using "UP/DOWN" and "SEL" key.
("UP/DOWN" key: change value, "SEL" key: moves item position.)
- 7) At the "GAIN" mode, "ABL" means ABL Level adjustment.
ABL Level adjusted using "UP/DOWN" key if necessary. (To meet the white peak "ft" level.)
- 8) Press "MODE" key to finish the "GAIN" or "BIAS" adjustment.

- 9) If you want to adjust other "GAIN" or "BIAS", Repeat from item C. "Color Adjustment".
- 10) Press "MODE" key again to finish the "COLOR" Adjustment.
- 11) If you want to finish factory adjustment, Select "RECALL" as item B. "Exit and save"

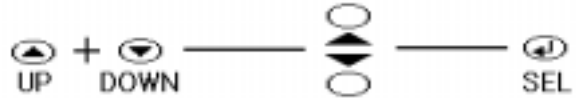

COLOR sub-menu

9300 GAIN	9300 BIAS
6500 GAIN	6500 BIAS



GAIN under sub-menu

RG 50	BG 50
GG 50	CO MAX

BIAS under sub-menu

RB 50	BB 50
GB 50	

HIGH VOLTAGE SHUT-DOWN CIRCUIT

The chassis of this monitor has been designed to emit a minimum of soft X-radiation, in accordance with US DHHS rules 21 CFR, subchapter. A high voltage shut-down circuit, as shown below, guarantees horizontal oscillation shut-down should the high voltage exceed designed picture tube maximums.

DO NOT ATTEMPT TO MODIFY THIS CIRCUIT.

A fly back pulse is generated at pin (4) of the fly back transformer.

After the pulse converted to DC through rectifying circuit D317 & C338, it is input to MCU pin (36) through the divider network register R627 & R637.

Normally voltage of R637 is below 3V, it is not operated but in case of excess voltage it has to be shut-down.

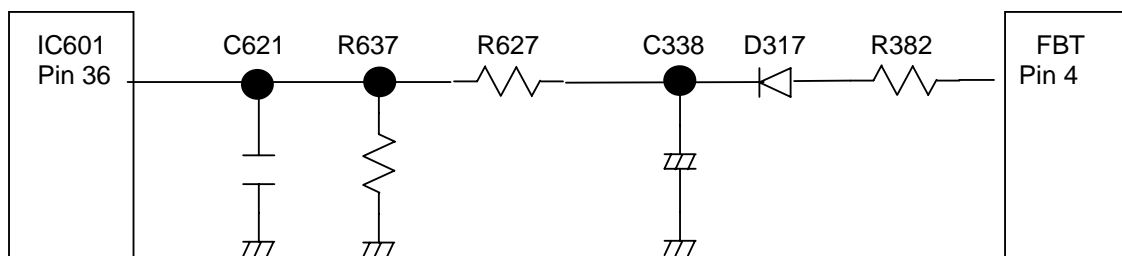

BLOCK DIAGRAM

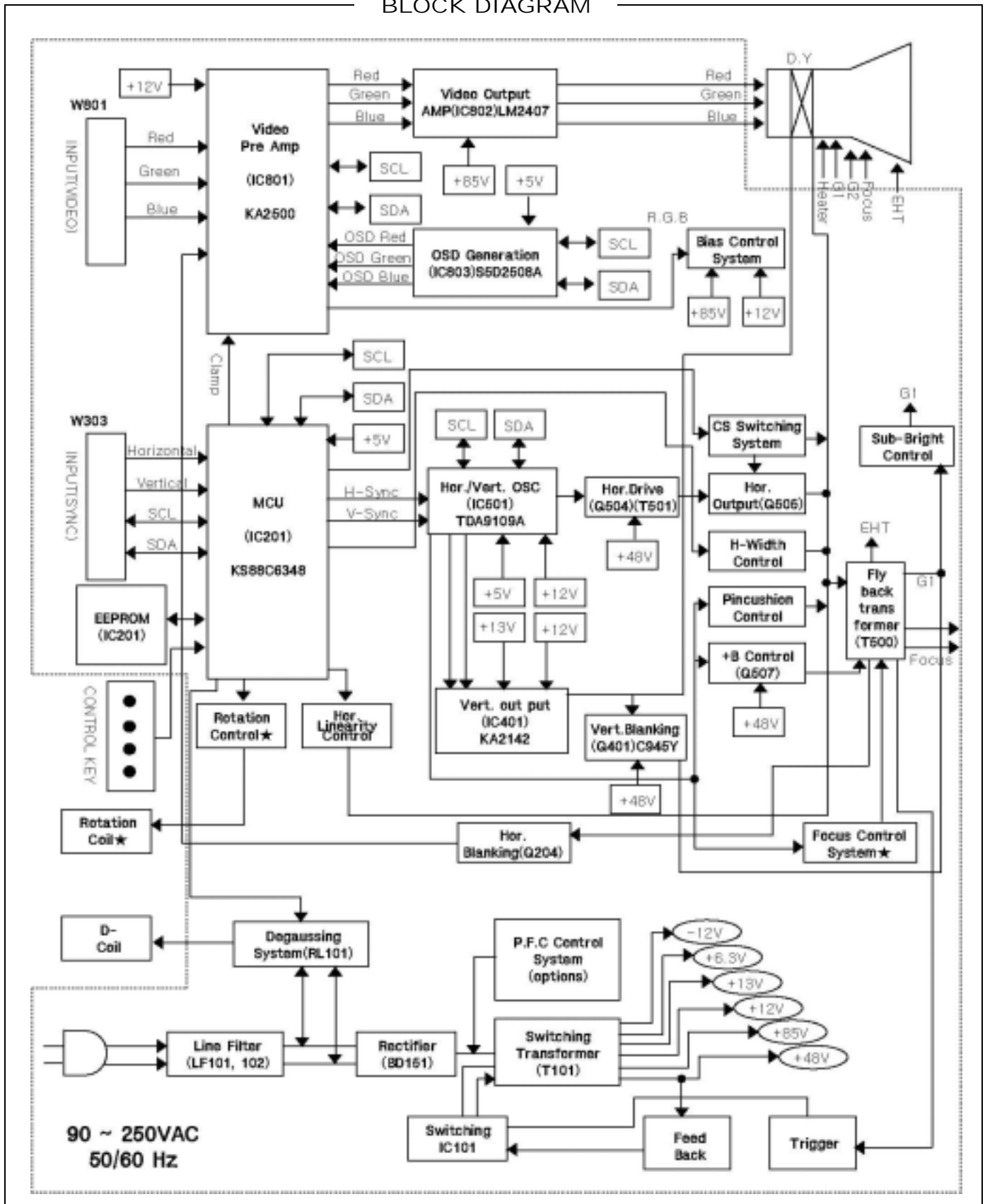

TROUBLE SHOOTING CHART

NO POWER

NO VIDEO

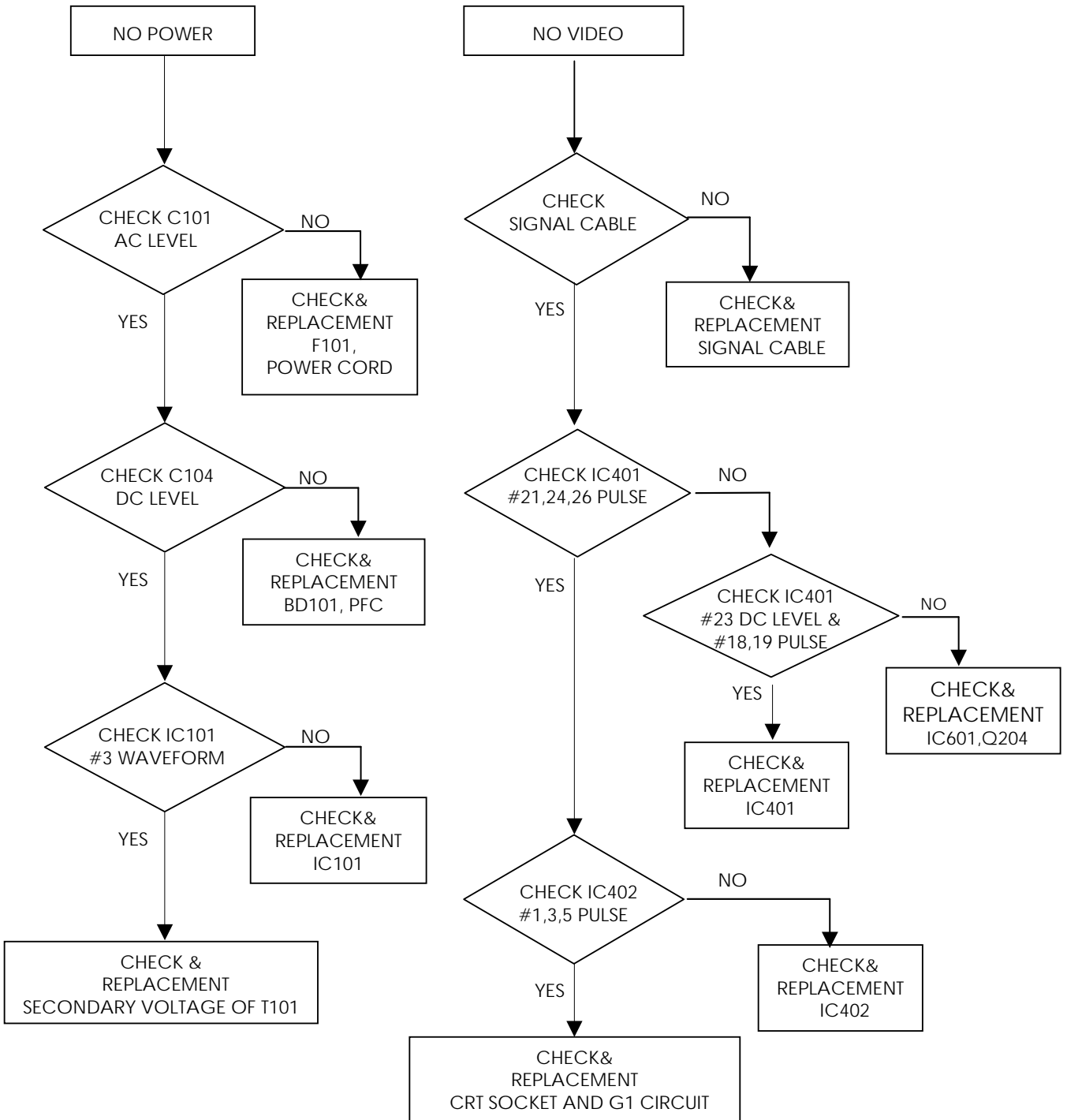

TROUBLE SHOOTING CHART

NO RASTER

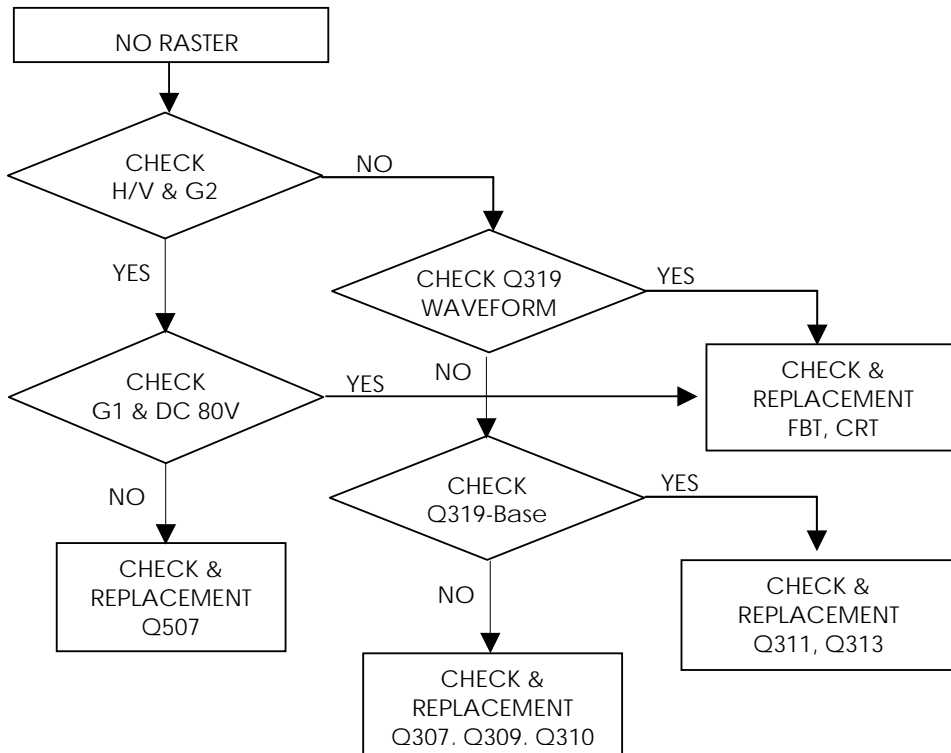

CONTRAST

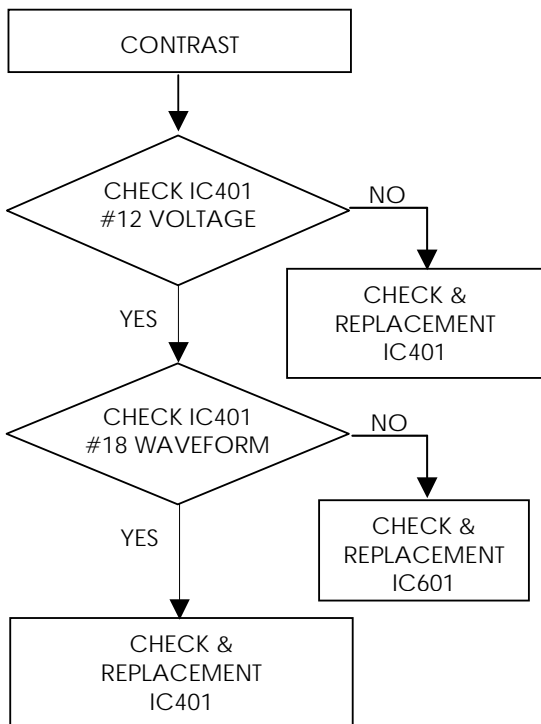

BRIGHTNESS

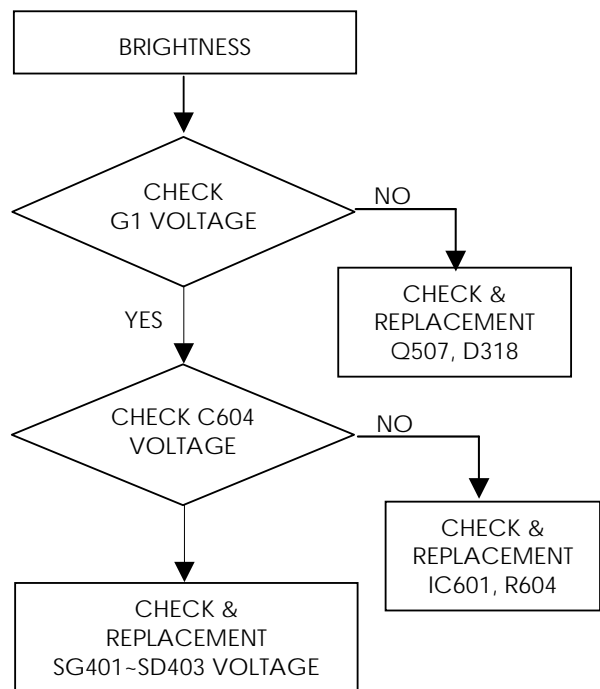

INTEGRATED CIRCUIT DIAGRAM

IC201 (u-COM) KS88C6348

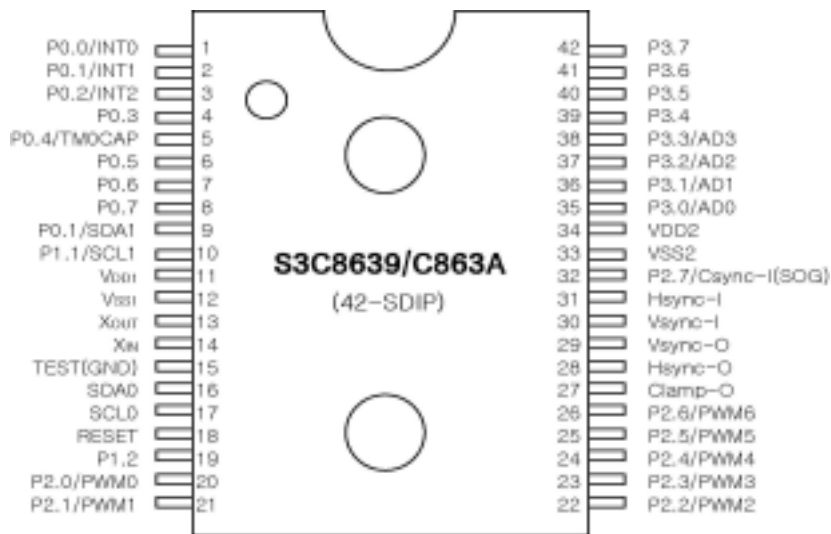
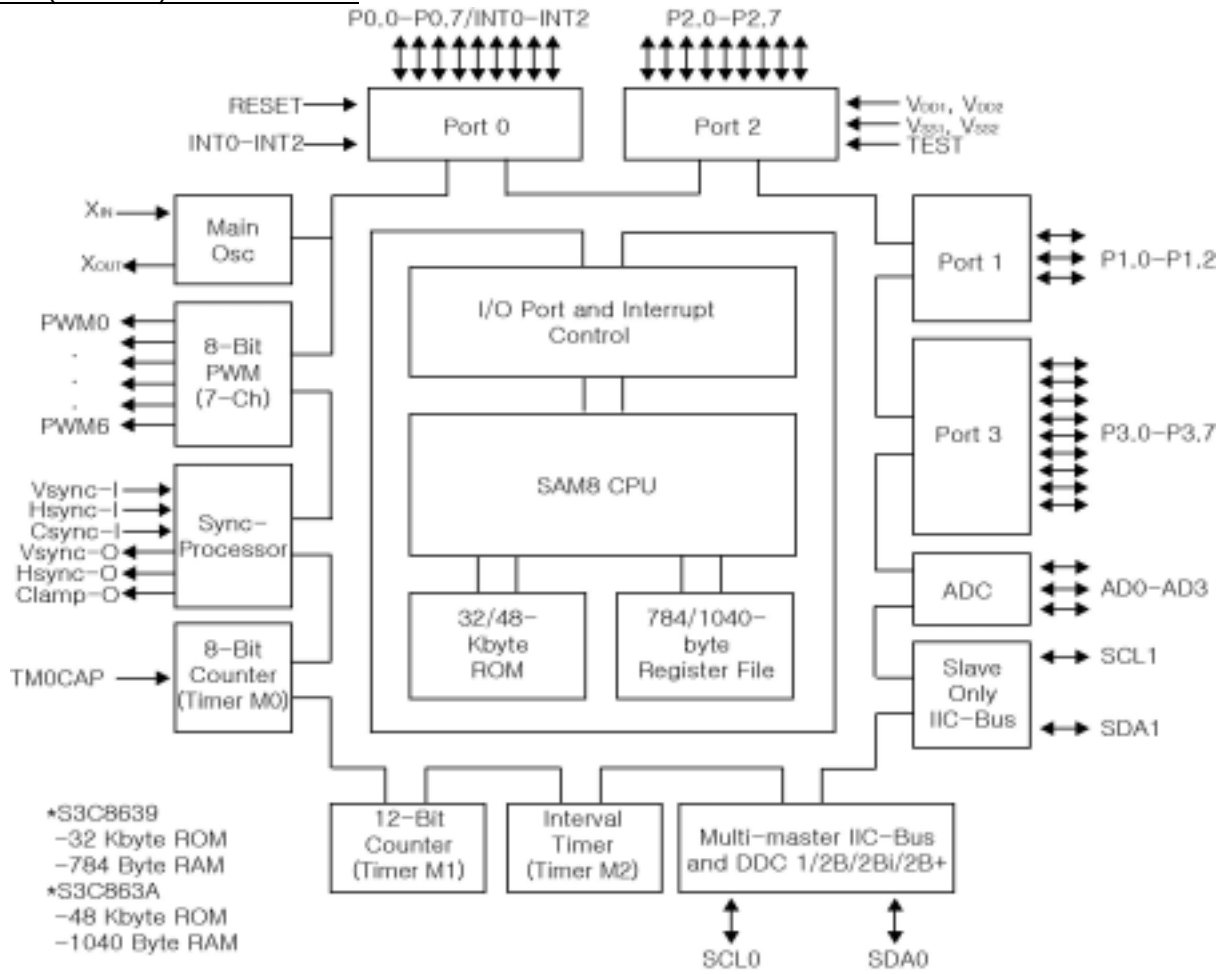

NOTE: The TEST pin must connect to Vss (GND) in the normal operation mode0

INTEGRATED CIRCUIT DIAGRAM

IC501 (IC HORIZONTAL&VERTICAL OSC.) TDA9109A

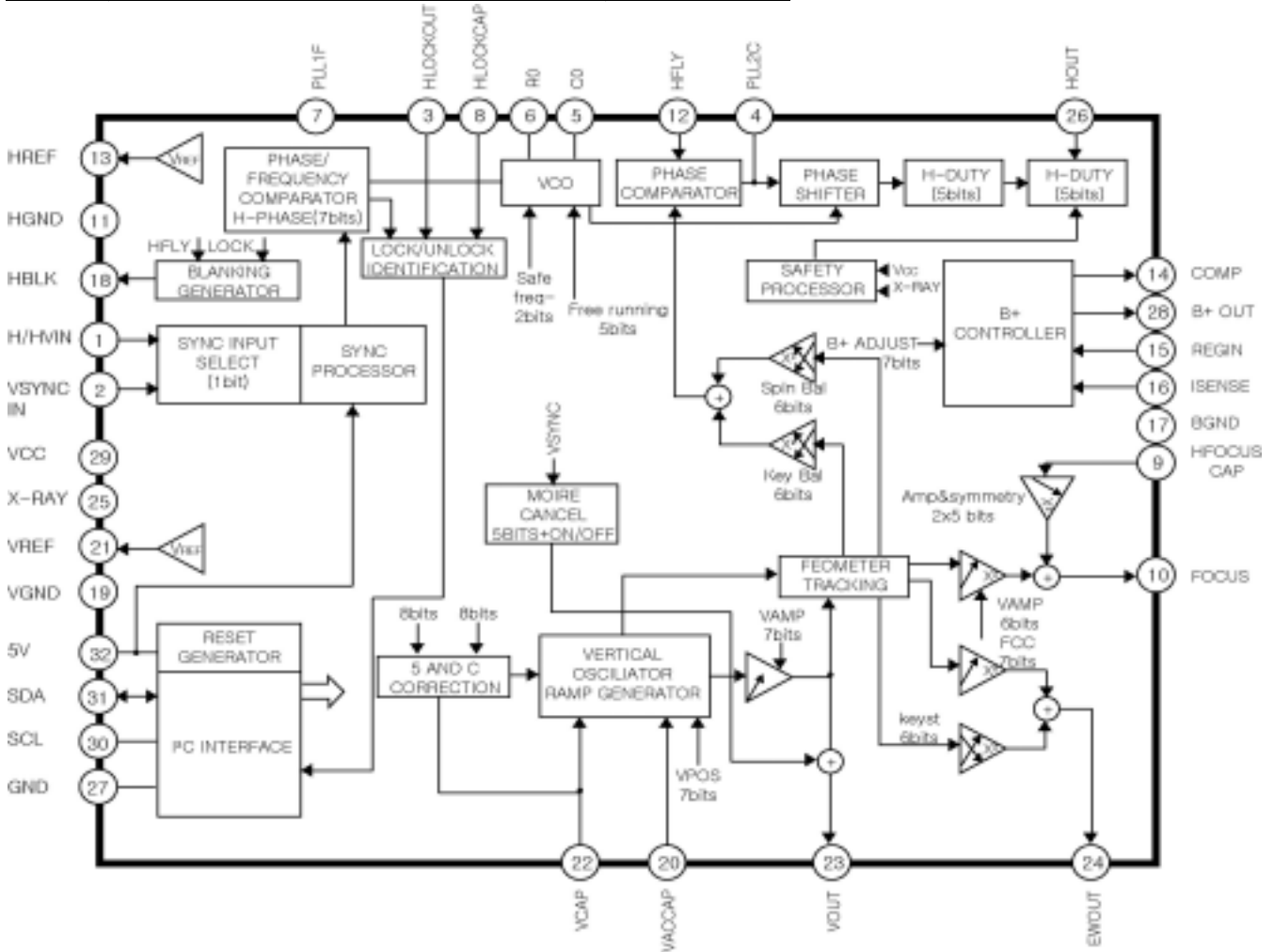

IC401 (IC VERTICAL OUTPUT) KA2142

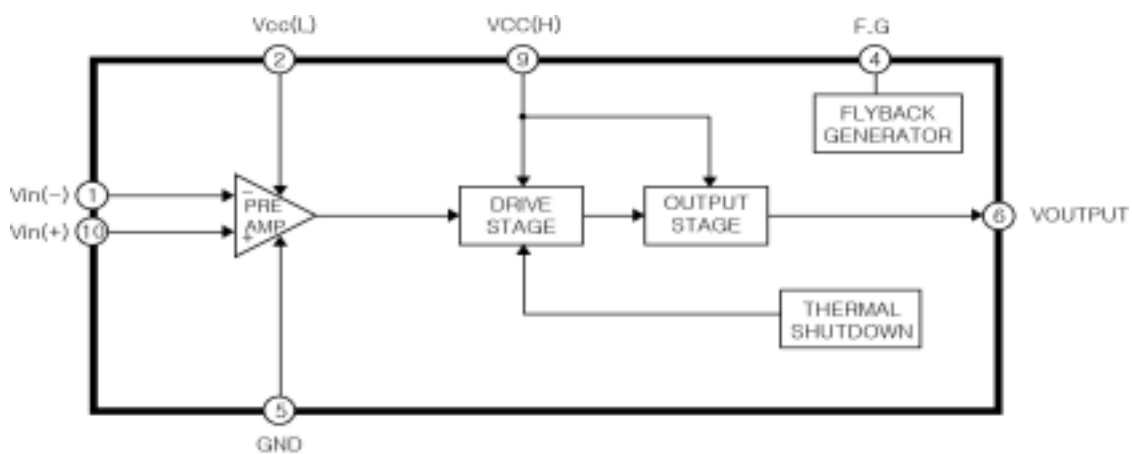

INTEGRATED CIRCUIT DIAGRAM

IC801 (IC VIDEO PRE-AMP.) KA2500B

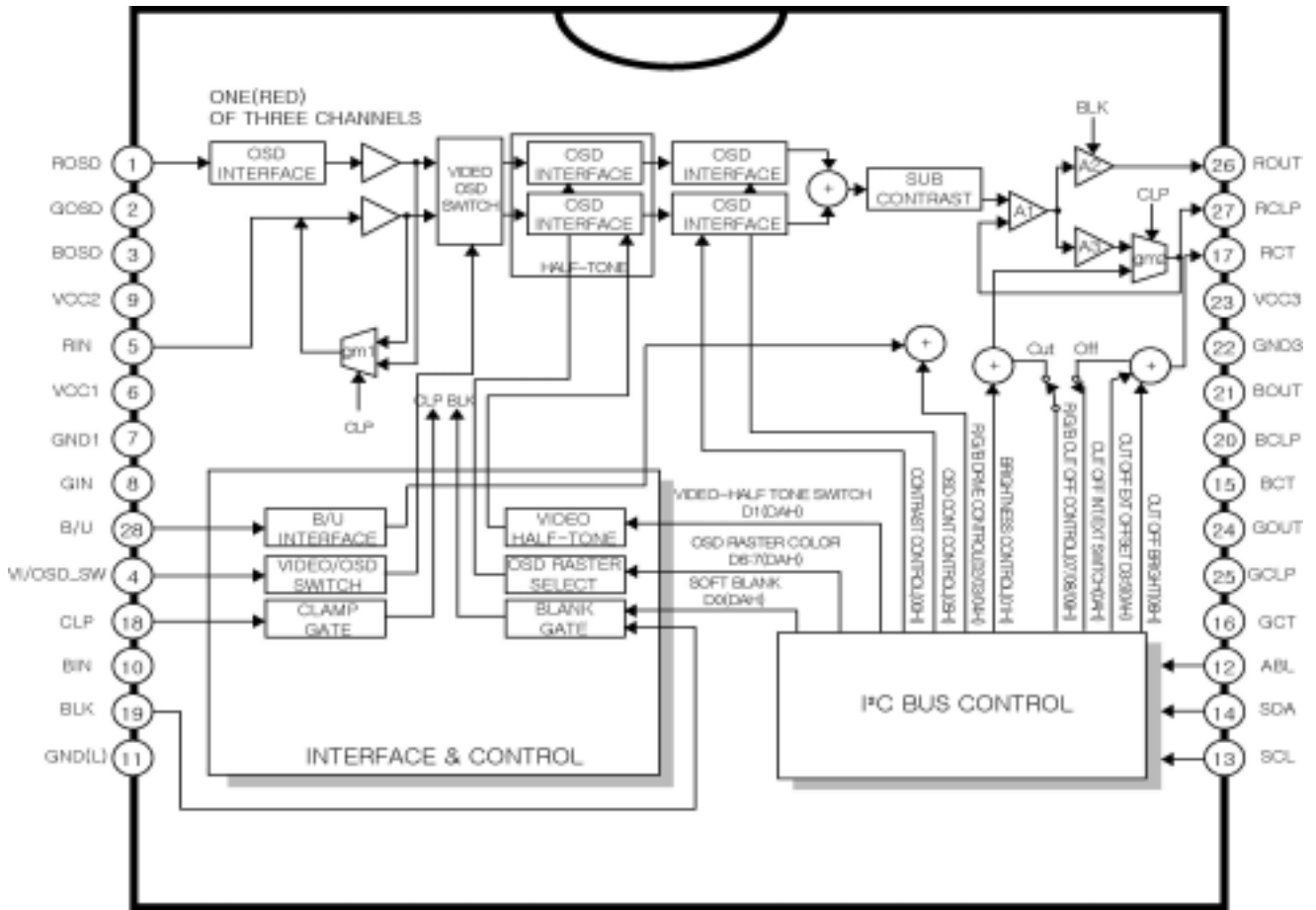

IC802 (IC VIDEO MAIN AMP.) LM2407

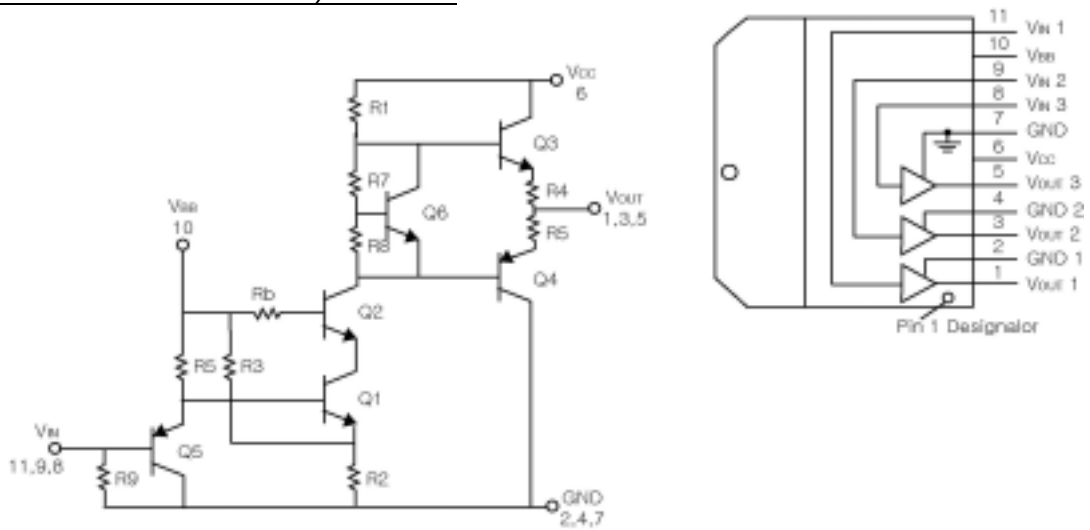

INTEGRATED CIRCUIT DIAGRAM

IC803 (IC ON SCREEN DISPLAY) S5D2508A

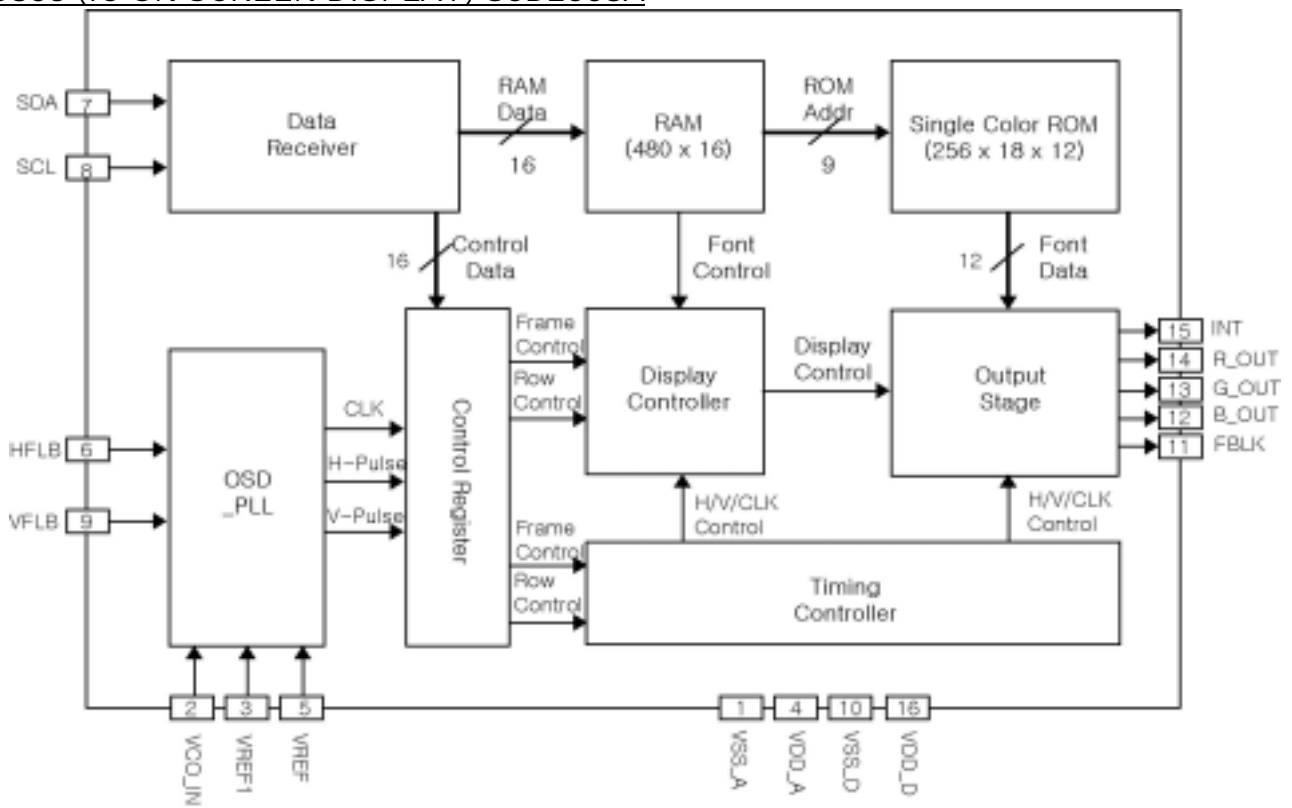

IC101 (IC SWITCHING REGULATOR) STR-F6656

